



# White Paper

## Air Cargo Digital Connectivity and Data Exchange Methodologies



Version	Amendment Description	Date	By
01	Initial Draft	22-Feb-2016	S. Tahir Hasnain (IATA)
02	Initial review, suggested changes	28-Feb-2016	Frederic Leger (IATA), N. Carlone (IATA)
03	Feedback and Improvements	21-Mar-2016	IATA Cargo Team, Cargo-XML Task Force, Strategic Partners and e-Cargo Technology Advisory Group
04	Feedback and Improvements	31-Mar-2016	IATA PAX team e-Cargo Strategic Partners
05	Feedback and Improvements	5-Apr-2016	Glyn Hughes (IATA)
06	Content Improvements	15-Apr-2016	IATA Publication Team
07	Brand Alignment	20-Apr-2016	IATA Corp. Communication
08	Review	30-May-2016	Cargo Operation and Technology Board (COTB)

---

## Table of Contents

1. Purpose .....	5
2. Target Audience.....	5
3. Background.....	5
4. Message Transmission Approaches .....	7
Figure 1: Methods to Connect Digitally.....	7
Figure 2: Connectivity Methodology Statistics .....	7
4.1 Host-to-Host Connectivity .....	7
Figure 3: Host-to-Host Connectivity Scenarios.....	8
Table 1: Challenges in Host-to-Host Connectivity .....	9
4.2 Connectivity via an Intermediary.....	9
Figure 4: Connectivity via an Intermediary .....	9
Figure 5: Carrier and Freight Forwarder Connectivity.....	10
Table 2: Challenges in Connectivity via an Intermediary .....	10
4.2.1 Value-Added Services by CCS.....	11
Figure 6: Basic and Value-Added Services Offered by CCSs.....	11
5. Digital Data Exchange Framework .....	11
Figure 7: Digital Data Exchange Framework .....	12
5.1. Messaging Standards .....	12
Table 3: Messaging Standards in the Air Cargo Industry.....	12
5.2 Communications Protocols .....	13
5.3 Trading Partner Identification and Addressing .....	13
Figure 8: Each Stakeholder Must Have a Unique Identifier and Address .....	14
5.3.1 Teletype Address .....	15
Table 4: Teletype Address .....	15
5.3.2 Auxiliary Code Address .....	15
Table 5: Auxiliary Code .....	15
5.3.3 Participant Identification and Message Addressing .....	16
Table 6: Participant Identification and Message Addressing.....	16
5.3.4 Third Party Reference .....	18
Table 7: Third party Reference.....	18
5.3.5 Other Identification Schemes .....	18
5.3.5.1 Cargo Account Settlement Systems (CASS).....	18

---

Table 8: Cargo Accounting Settlement Systems .....	19
5.3.5.2 <i>D-U-N-S Number</i> .....	19
5.4 Challenges in Identification and Addressing .....	20
6. Moving Forward .....	21
Figure 9: Requirements for Digital Transformation in the Air Cargo Industry .....	21
Figure 10: Global Identity Management Solution.....	22
7. Summary .....	23

---

## 1. Purpose

The purpose of this white paper is to serve as a guide for the air cargo industry towards efficiently connecting and exchanging digital information with business partners across the supply chain. This paper reviews various digital connectivity methodologies and outlines challenges associated with each method.

This document identifies the basic components of the digital framework and pinpoints gaps by analyzing its deployment in air cargo. Finally, this paper emphasizes the need for standardized business processes for the air cargo digital framework. It also establishes the guidelines that are instrumental in addressing existing challenges as well as facilitating the adoption of modern technology.

## 2. Target Audience

This document is intended for air cargo stakeholders who are directly or indirectly involved in digital connectivity and data exchange. These include carriers, freight forwarders, ground handlers, shippers, custom authorities, IT/messaging service providers and international organizations, including IATA.

## 3. Background

Electronic data interchange has played a significant role in allowing the air cargo industry to operate more efficiently. Traditionally, the air cargo industry has relied on proprietary networks for digital data transmission such as Type B. Different systems (both internal and external) are interconnected using these networks and exchange information using IATA standard messages such as Cargo-IMP and Cargo-XML. The proprietary networks provide a secure, reliable and real-time information exchange. For operational purposes, these networks support the instant messaging requirements in all business areas such as passenger, cargo and baggage.

While these proprietary networks support the airline industry business processes very well, recent modernization of the Internet and other new technologies are challenging the proprietary networks and exposing their many shortcomings and weaknesses. For example, Cargo-XML standards are not supported over the Type B network. As the airline industry continues to embrace modern technology, it is inevitable that they will ultimately diverge from the proprietary networks. We see evidence of this today as airlines use the latest cloud-based technology and portable devices (i.e., iPads and handheld scanners) in their internal systems and applications. However; digital data exchanges with partners are leveraged using proprietary networks and require Internet-based communication channels and tools.

For new players, participation in the air cargo digital exchange remains a mystery (confusing and complex) because connectivity prerequisites are unknown and the business processes are not well defined.

---

For new players, participation in the air cargo digital exchange remains a mystery (confusing and complex) because connectivity prerequisites are unknown and the business processes are not well defined. For existing stakeholders, migration from proprietary networks to Internet-based communication channels is challenging due to the lack of standard business processes, rules and guidelines.

For existing stakeholders, migration from proprietary networks to Internet-based communication channels is challenging due to the lack of standard business processes, rules and guidelines.

Air cargo stakeholders who have embraced new technologies and solutions often face challenges when trying to exchange digital information with their partners across the supply chain. In the air cargo industry, the digital data transmission capabilities of an individual company are highly contingent by the technical capabilities of its partners.

In the air cargo industry, digital data transmission strategy of an individual company is highly influenced by the technical capabilities of its partners.

The recurring questions being asked are:

*“What do I need to do in order to connect with the partner airline/freight forwarder?”*

*“How can I find out who is using which communication channel?”*

*“Where can I find out which messaging standards are supported by my partner?”*

These questions were not raised in the past because the proprietary networks were managing the entire communications process and were the only custodians of this information. New technologies have demonstrated that the air cargo industry must establish clear guidelines and standards around connectivity in order to begin seamlessly adopting new technologies and making them more competitive.

The next section takes a deeper look at the different digital connectivity methodologies that are currently used in air cargo.

## 4. Message Transmission Approaches

Air cargo business processes are heavily reliant on digital information exchanges between multiple parties. Essentially, there are two methods to connect digitally and, based on a party's specific business requirements, one can adopt either or both. The two methods are described in Figure 1:

**Figure 1: Methods to Connect Digitally**

**Method 1:** Host-to-Host Connectivity

**Method 2:** Connectivity via an intermediary

The graphic depicts the message transmission approaches currently being adopted in the air cargo industry.

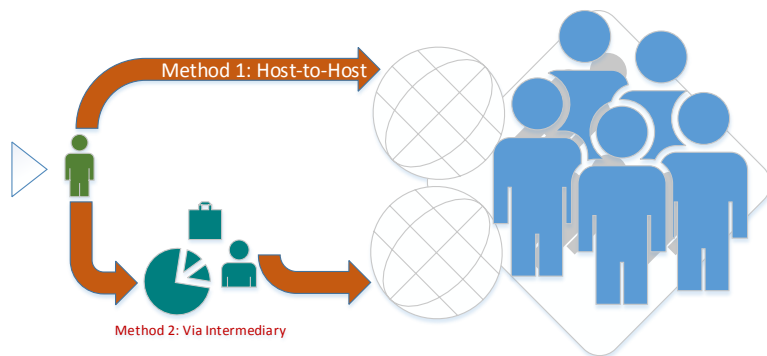

As at Q1 2016, industry digital communication is dominated by Method 2 (i.e., connectivity via an intermediary). Figure 2 depicts the latest statistics for connectivity methodologies between airlines and freight forwarders.

**Figure 2: Connectivity Methodology Statistics**

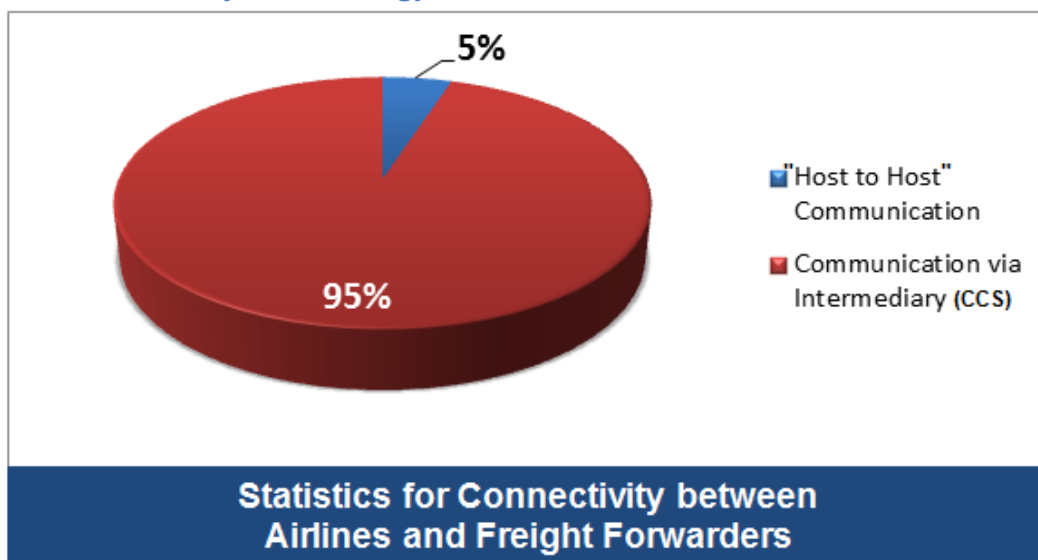

### 4.1 Host-to-Host Connectivity

In this method, two stakeholders communicate directly (host-to-host) with each using identical communication protocols. Figure 3 depicts the Host-to-Host connectivity scenarios.

### Figure 3: Host-to-Host Connectivity Scenarios

In today's world, while electronic communication is essential for every stakeholder, the requirements (i.e., security, reliability, and authentication) may vary from one stakeholder to another. Stakeholders, therefore, adopt a communication channel based on their requirements. The air cargo industry, therefore, has adopted heterogeneous communication protocols fulfilling individual stakeholder requirements, including the proprietary networks.

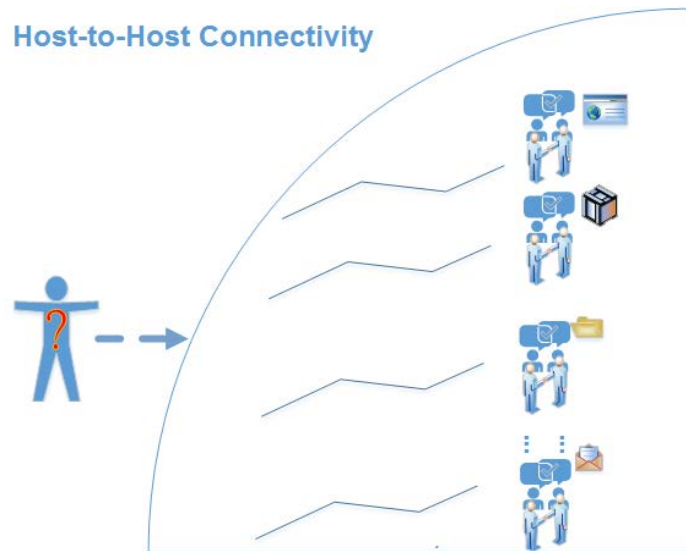

Due to this heterogeneity of protocols, in Host-to-Host communication, one must support all the communication protocols implemented by the partners - a complicated and laborious exercise. Due to these challenges, Host-to-Host connectivity is not a popular approach in the air cargo industry.

Only a limited number of stakeholders use the Host-to-Host connectivity approach and, even for those stakeholders, it is not their preferred method of connectivity. As at Q1 2016, Host-to-Host communication constitutes less than 5% of the total air cargo communications between airlines and freight forwarders.

As of Q1 2016, Host-to-Host communication constitutes less than 5% of the total air cargo communications between airlines and freight forwarders.

Partners engaged in Host-to-Host connectivity prefer TCP/IP (Transmission Control Protocol/Internet Protocol) or web-based communication protocols such as FTP, SMTP and web services over proprietary networks to reduce the cost of infrastructure requirements. Some companies are offering cloud-based connectivity solutions via the software-as-a-service (SaaS) model. Cloud-based solutions allow global accessibility as well as easier collaboration and administration.

In Host-to-Host communication, one must support all communication protocols implemented by the partners; therefore it is not a popular approach in air cargo industry.



**Table 1: Challenges in Host-to-Host Connectivity**

For a small number of connections, it is relatively convenient to connect directly. Management and maintenance, however, get more complicated as the number of connections grows. Some of the challenges associated with the Host-to-Host connectivity approach are listed here:

- Challenges**
- *Requires bilateral agreements between the partners*
  - *Requires additional maintenance and support for multiple communications channels*
  - *Requires multiple software licenses*
  - *Limited adoption*
  - *Lack of a central repository for who is using which communication protocol*

## 4.2 Connectivity via an Intermediary

Connecting via an intermediary involves exchanging data through a third party that specializes in electronic data interchange services. This method is commonly used in the air cargo industry and these intermediaries are known as messaging service providers or cargo community system (CCS) providers. Figure 4 depicts the connectivity via an intermediary scenario.

**Figure 4: Connectivity via an Intermediary**

CCS providers offer integrated platforms to air cargo stakeholders for data sharing and reuse. CCS providers generally adhere to IATA messaging standards and provide solutions for regulatory compliance. CCS providers support heterogeneous protocols ranging from the proprietary to modern web-based communications.

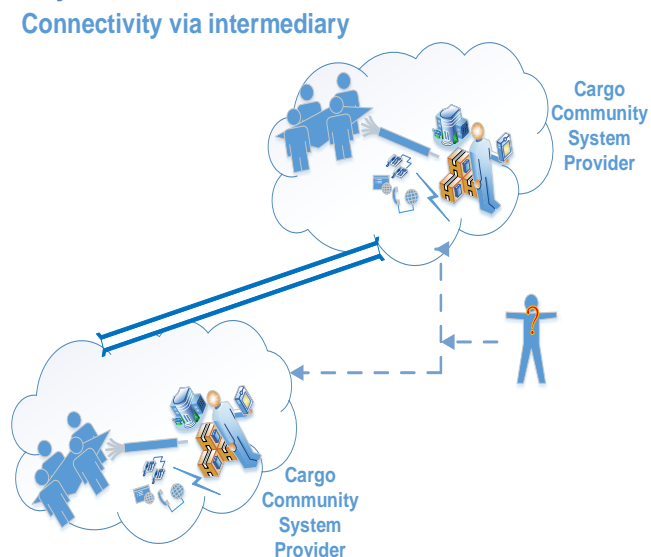

At present, air cargo data is mostly exchanged using CCS and connecting through intermediaries is a very popular and preferred approach to air cargo communications. As at Q1 2016, Connectivity via Intermediary constitutes more than 95% of the total air cargo communications between airlines and freight forwarders.

**As at Q1 2016, Connectivity via Intermediary constitutes more than 95% of the total air cargo communications between airlines and freight forwarders.**

Stakeholders connected with any particular CCS comprised the community of that CCS. In order to transmit data via a CCS, one needs to establish a single communication channel with that specific CCS. Once that communication channel is established, one can exchange messages with all other entities connecting to that specific CCS. Furthermore, different CCS providers collaborate and interconnect with each other, making it possible for stakeholders connected to one CCS to exchange information with stakeholders connected to a different CCS.

Different CCS providers collaborate and interconnect with each other, allowing their community members to exchange information with the communities of other CCSs.

A typical model of Carrier and Freight Forwarder connectivity is depicted below in Figure 5.

**Figure 5: Carrier and Freight Forwarder Connectivity**

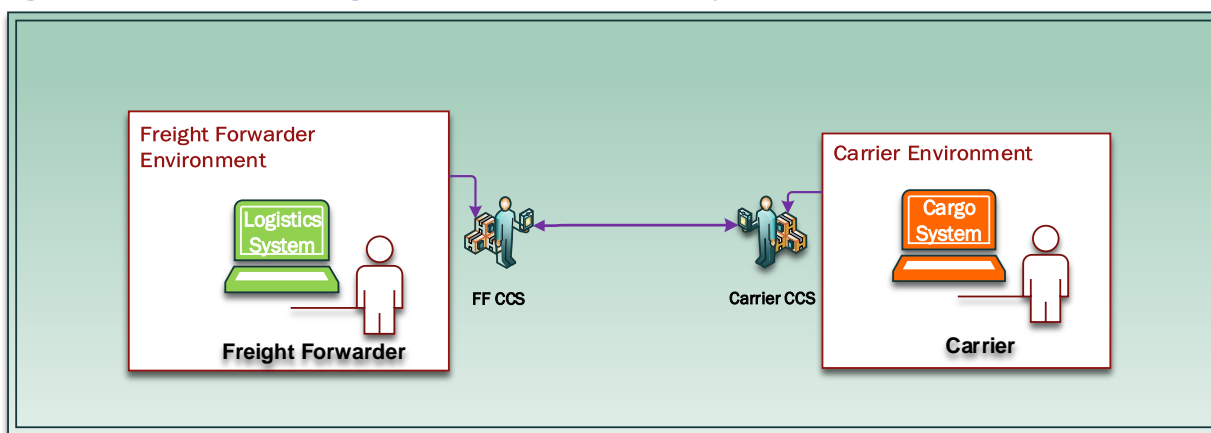

It is quite possible that both the Airline and Freight Forwarder are connected to a common CCS. Also, for commercial and operational reasons, it is possible for one stakeholder to join multiple communities directly.

**Table 2: Challenges in Connectivity via an Intermediary**

While different CCSs seamlessly connect their members with each other and form a global community, there are challenges associated with this approach. Some of these challenges are encountered by the CCSs themselves while others are encountered

#### Challenges

- *Lack of a standardized registration process*
- *No prerequisites defined for customers*
- *Lack of standard business processes between airlines, freight forwarders and CCSs for issuing and sharing IDs*
- *Complex problem-solving when multiple CCSs are involved*
- *Switching from one CCS to another is complicated*

by the users, including airlines, freight forwarders, etc. Some challenges are so severe that they prevent technology advancements in the air cargo industry and require immediate resolution. The common challenges are listed here:

- *Lack of end-to-end visibility (track and trace) on the customer end*
- *Lack of transparency on the customer end*
- *Technical details (i.e., comm. protocol) of a customer remain with its CCS partner*
- *Lack of a central repository for who is using which communication protocol*

#### 4.2.1 Value-Added Services by CCS

Over the years, CCSs have expanded the scope of their services to non-traditional players in the air cargo supply chain such as customs authorities and regulators. While connectivity remains the basic service for CCSs, they are now offering a number of value-added services and products (e.g., portals and applications). Figure 6 provides a high level overview of basic and value-added services offered by CCSs.

**Figure 6: Basic and Value-Added Services Offered by CCSs**

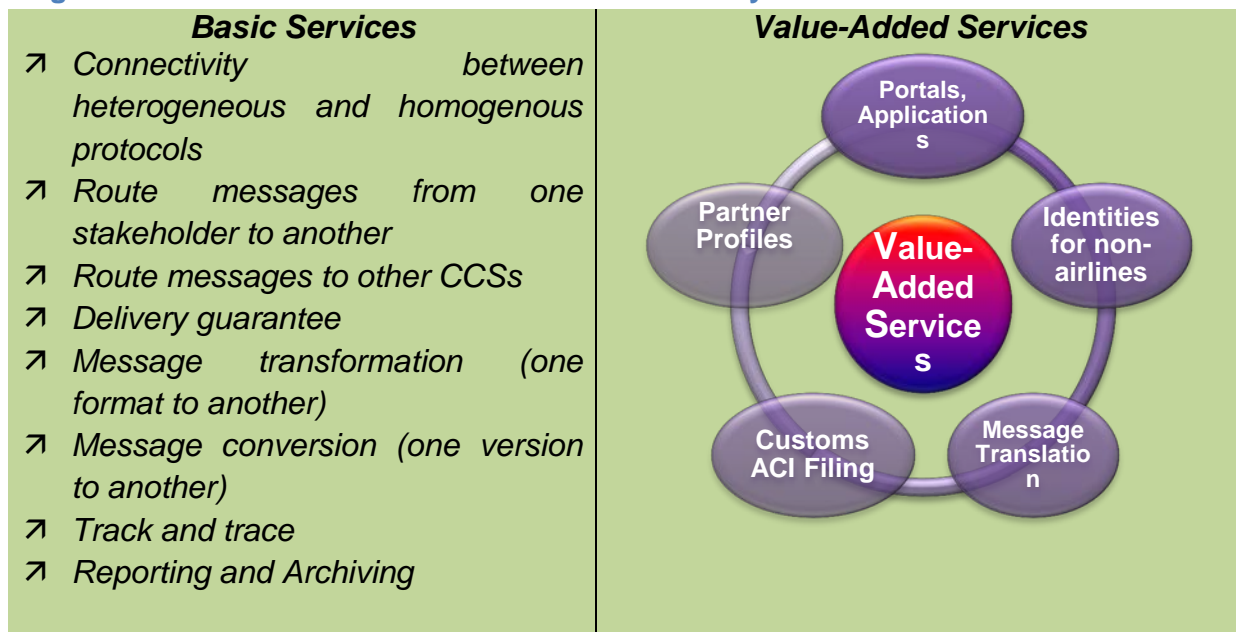

## 5. Digital Data Exchange Framework

Generally, there are three key components of digital connectivity. As a prerequisite, each player involved in electronic interchange must conceive and adhere to these components:

- Messaging Standards
- Communications Protocols
- Trading Partner Identification and Addressing

**Figure 7: Digital Data Exchange Framework**

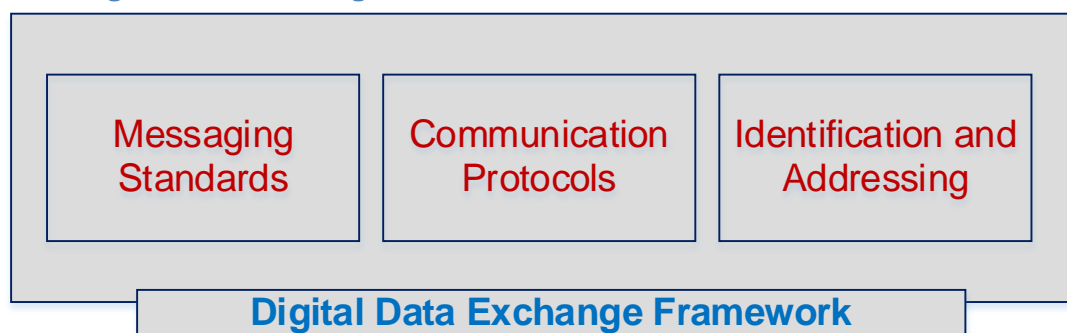

### 5.1. Messaging Standards

Messaging standards allow for the exchange of data via electronic means. By adhering to the same standard, different entities can electronically exchange documents such as air waybills and flight manifests.

Two messaging standards are available in the air cargo industry:

**Table 3: Messaging Standards in the Air Cargo Industry**

Cargo-XML (emerging)	Maintained by the Cargo-XML Task Force (CXMLTF)	Published in the Cargo-XML Manual and Toolkit
Cargo-IMP (traditional)	Formerly maintained by the Cargo Data Interchange Task Force (CDITF)	Published in the Cargo-IMP Manual

Following demand from the industry, the IATA Cargo Services Conference (CSC) decided to freeze Cargo-IMP Messages and discontinue the IATA Cargo-IMP Manual. Effective 1 January 2015, the Cargo-IMP Manual, 34<sup>th</sup> Edition, is the final edition and there will be no further changes made to the Cargo-IMP Messages. The Cargo-IMP standard can continue to be used; however, future developments of messaging standards will occur in the Cargo-XML standard only.

The air cargo industry is in the early stages of implementing the Cargo-XML standard. IATA published a white paper aimed at facilitating industry adoption of the Cargo-XML standard by providing different implementation strategies, migration approaches and the necessary guidelines. This paper also discusses the role of different stakeholders in adopting the Cargo-XML standard and contains information about different tools and resources available from IATA for Cargo-XML adoption. The Cargo-XML White Paper is available at: <http://www.iata.org/whatwedo/cargo/e/Documents/cargo-xml-standards-white-paper.pdf>

---

## 5.2 Communications Protocols

For the most part, the air cargo sector relies on proprietary communications protocols. However, the industry also supports a number of modern Internet-based protocols as well. There are a number of communications protocols in the air cargo industry that use either Host-to-Host connectivity or a messaging intermediary. Some of these communications protocols are proprietary while others are open source. Examples include:

- [SSH](#) Secure Shell
  - [FTP](#) File Transfer Protocol
  - [SMTP](#) Simple Mail Transfer Protocol
  - [HTTP](#) Hyper Text Transfer Protocol
  - [HTTPS](#) Secure Hyper Text Transfer Protocol
  - [SFTP](#) Secure File Transfer Protocol
  - [SSL](#) Secure Socket Layer\*
  - [TLS](#) Transport Layer Security\*
  - [POP](#) Post Office Protocol
  - [Web Services](#) HTTP-based web services
  - [SOAP](#) Simple Object Access Protocol
  - [MATIP](#) Mapping of Airline Traffic over Internet Protocol
  - [AS1/AS2](#) Applicability Statement 1/2
  - [Type B](#) SITA's Type B Messaging Service
  - [Type X](#) SITA's Type X Distribution Service
  - [MQ Series](#) messaging middleware from IBM
  - [AS4](#) Applicability Statement 4
- \* used with other protocols.

**Note:** In 2014, the IATA e-Cargo Electronic Technical Advisory Group (e-TAG) recommended AS4 as a standard communication protocol for air cargo digital exchanges. However, it is less likely that AS4 will be a common protocol for the air cargo community due to:

- The availability of low-cost/free communication protocols (i.e., SFTP, SMTP)
- CCS continuous support for existing communications protocols
- Costly migration/adoption of AS4

It is important to note that AS4 is a relatively new protocol and will likely evolve with advancement in technology.

## 5.3 Trading Partner Identification and Addressing

Identification and addressing are fundamental to digital connectivity. For the air cargo industry, irrespective of the connectivity method used, the sender and recipient identification and addressing remains the most challenging aspect of digital communication. As a prerequisite, each stakeholder involved in electronic interchange must have a unique identifier and address to successfully communicate with other parties.

As a prerequisite, each stakeholder must have a unique identifier and address to successfully communicate with other parties.

A unique identification and a robust addressing scheme are two fundamental components of electronic connectivity and the time has come for the air cargo sector to ask itself two fundamental questions:

*“Do all the stakeholders have a unique permanent identification?”*

*“Do all the stakeholders have a unique addressing mechanism?”*

The answer to these two questions is “No” because a unique identification system does not exist nor is there a single organization in air cargo industry issuing identifiers. Also, addressing mechanisms are highly complex and differ from one stakeholder to another.

**Figure 8: Each Stakeholder Must Have a Unique Identifier and Address**



Let's first understand the different identification and addressing mechanisms that currently exist in the air cargo industry.

In the air cargo industry, identification and addressing methods vary from one stakeholder to another. The identification and addressing methods currently being used in the industry are:

- Teletype Address (TTY)
- Auxiliary Codes
- Participation Identification and Message Addressing Scheme (PIMA)
- Email Address

In the air cargo industry, it is common that one stakeholder retains or uses multiple identifications and different addressing methods.

In the air cargo industry, it is common that one stakeholder retains or uses multiple identifications and different addressing methods.

Below is a summary and an analysis of the identification and addressing methods used by different stakeholders.

### 5.3.1 Teletype Address

**Table 4:** Teletype Address

Method:	Teletype Address
Issued by:	IATA ( <i>Note: IATA issues airlines two-letter codes and a scheme for composing the address</i> )
Maintained by:	SITA, ARINC and AVFINITY
Published by:	Not published
Size:	7 characters
Syntax:	Airport code (3 letters) + office designator (2 letters) + airline code (2 letters)
Example:	ZRHFMLX where <b>ZRH</b> is airport code, <b>FM</b> is the Freight/Cargo System, and <b>LX</b> is the two-letter airline code for Swiss Air
<i>Special Note:</i>	<i>The same schema is applicable to other airline functional areas such as Passenger and Baggage Services, ULD and Ground Handling.</i>

### 5.3.2 Auxiliary Code Address

**Table 5:** Auxiliary Code

Method:	Auxiliary Code
Issued by:	Airlines for America (A4A) through SITA, AIRINC, AVFINITY
Maintained by:	A4A
Published by:	<i>IATA (Airline Coding Directory)</i>
Size:	7 characters
Syntax:	Airport code (3 letters) + office designator (2 letters) + auxiliary code (2 letters)

	<p><u>Note: the following auxiliary codes are applicable:</u></p> <p><b>CR</b> Car rental companies/Miscellaneous  <b>HL</b> Hotel/Motel companies  <b>XA</b> ARINC  <b>XB</b> IATA  <b>XD</b> A4A  <b>XH</b> Special ground handling service  <b>XI</b> AEI  <b>XS</b> SITA  <b>YA</b> Government Civil Aviation/Government  <b>YY</b> General addressing  <b>ZZ</b> Computer tests  <b>2X/6X/7X/8X</b> Miscellaneous  <b>X2/X6</b> Non-scheduled air transportation  <b>GN</b> General aviation</p>
Example:	<p>LHRAE7X  where <b>LHR</b> is the airport code, <b>AE</b> is Air Express, and <b>7X</b> is the auxiliary code for DHL Global Forwarding.</p>

### 5.3.3 Participant Identification and Message Addressing

**Table 6: Participant Identification and Message Addressing**

Method:	Participant Identification and Message Addressing (PIMA)
Issued by:	Cargo Community System (CCS) providers (Note: IATA issues a scheme for PIMA format)
Maintained by:	Cargo Community System (CCS) providers
Published by:	Not available publically
Size:	33 characters
Syntax:	CCS System Identifier + CCS Group Code + CCS Code Type + CCS Participant Identifier + Separator + Airport/City Code + CCS Participant Office



---

Example:	TDVAGT03MERIDIAN/ATL1 where <b>TDV</b> is the CCS Identification, <b>AGT</b> is the Group Code, <b>03</b> is the code for the Agent, <b>MERIDIAN</b> is the Agent Name, <b>/</b> is the separator, <b>ATL</b> is the airport/city code, and <b>1</b> is the Participant Office
----------	---

---

### 5.3.4 Third Party Reference

**Table 7: Third party Reference**

Method:	Third Party Reference (TPR)
Issued by:	Cargo Community System (CCS) Providers
Maintained by:	Cargo Community System (CCS) Providers
Published by:	Not available publically
Size:	7 characters
Syntax:	Agent Name (4 characters) + City Code (3 characters) Note: The TPR can vary and can also contain a three-character Agent Name and a three-character City Code plus a one-character number (e.g., KUEVIE1)
Example:	CEVAIAH Where <b>CEVA</b> is the agent name and <b>IAH</b> is the city code

### 5.3.5 Other Identification Schemes

The above identification schemes are available for digital connectivity; however, there are other identification schemes available for different purposes.

#### 5.3.5.1 Cargo Account Settlement Systems (CASS)

For billing and settlement between airline and freight forwarders, Freight Forwarders that are part of the IATA Cargo Account Settlement Systems (CASS) use different identifications assigned by IATA. CASS operates through [CASSLINK](#) an advanced, global, web-enabled e-billing solution.

**Table 8: Cargo Accounting Settlement Systems**

Method:	Cargo Accounting Settlement Systems (CASS)
Issued by:	IATA
Maintained by:	IATA
Published by:	IATA
Size:	11 characters
Syntax:	Geographical Designator (2 digits) + Area Designator (1 digit) + Location Designator (4 digits) + Slash + CASS Code (3 digits) + Check Digit (1 digit)
Example:	3847028/0203 is the CASS number for DHL Global Forwarding (Italy), where: <ul style="list-style-type: none"><li>▪ <b>38</b> is the geographic designator</li><li>▪ <b>4</b> is the area designator</li><li>▪ <b>7028</b> is the location designator</li><li>▪ <b>/</b> is the slash</li><li>▪ <b>020</b> is the CASS number</li><li>▪ <b>3</b> is the check digit*</li></ul> * The check digit is calculated from the first 10 digits using a modulus 7 approach.

### 5.3.5.2 D-U-N-S Number

The D-U-N-S Number is a unique nine-digit number that identifies business entities on a location-specific basis. These are assigned and maintained by [Dun & Bradstreet \(D&B\)](#).

It is used to establish a Dun & Bradstreet business credit file, which is often referenced by lenders and potential business partners to help predict the reliability and/or financial stability of the company in question.

---

## 5.4 Challenges in Identification and Addressing

Teletype identification and addressing has served the airline industry for the last five decades and so has the PIMA scheme for freight forwarders. The common challenges faced by the industry regarding these methods are:

- Getting an identity is an ambiguous and cumbersome process
- Identity management procedures and schemes differ from one stakeholder to another (hence, identities are not harmonized)
- Not all stakeholders have permanent identities
- No centralized repository for identities and addresses
- Maintenance of identities is challenging

## 6. Moving Forward

During the last decade, with the evolution of technology, the air cargo industry has been trying to keep pace with its e-commerce and digitization capabilities. However, some fundamental components of digital exchange (such as identification and addressing) have been somewhat overlooked. It is quite evident that air cargo lacks the global standards, harmonized procedures and a central repository needed for identity and addressing management.

Identity management and addressing serve as the foundation of air cargo digital communication. Until the challenges surrounding identity and addressing are addressed properly, the air cargo industry will struggle to embrace new technologies

Identity management and addressing serve as the foundation of air cargo digital communication. Until the challenges surrounding identity and addressing are addressed properly, the air cargo industry will struggle to embrace new technologies and continue its reliance on CCS.

Ideally, identities should be recognized and accessible by all stakeholders. There is an urgent need to set up a business process around issuing, managing and distributing these identities. Addressing the requirements in Figure 9 below will set a strong foundation for digital transformation in the air cargo industry.

**Figure 9: Requirements for Digital Transformation in the Air Cargo Industry**

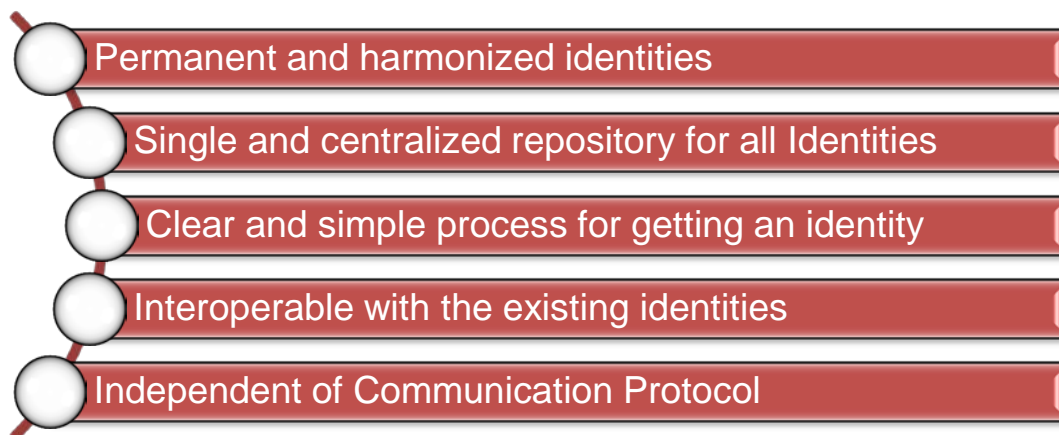

---

There is a strong need to have a centralized Identity Management Solution that issues and distributes unique identities for all parties in the air cargo digital exchange. Figure 10 depicts the global identity management solution.

**Figure 10: Global Identity Management Solution**

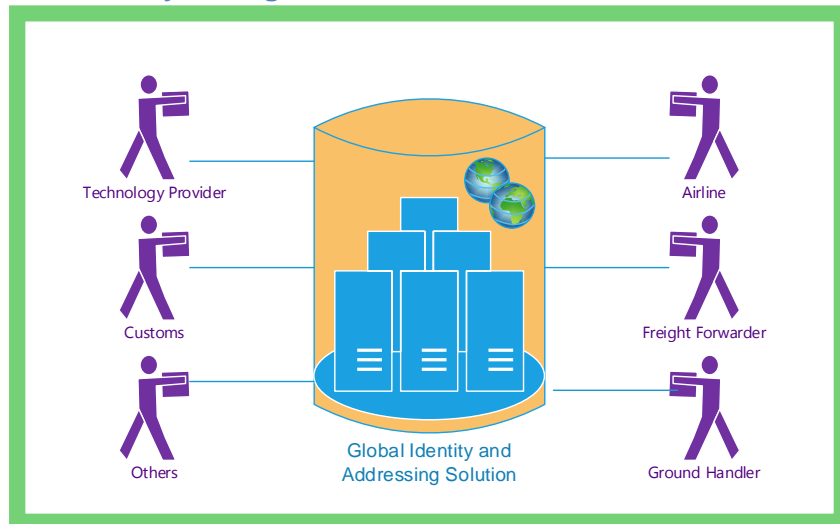

---

## 7. Summary

The air cargo industry is moving progressively towards digital transformation. Even though technology penetration, digital connectivity and infrastructure vary across the supply chain, digital transformation remains inevitable. The industry is versatile and stakeholders expect autonomy, however, digital collaboration with business partners is becoming a necessity throughout the supply chain.

While the industry leverages multiple techniques and methodologies for digital transmission, there is an ultimate need to harmonize the basic principles allowing individual stakeholders to adhere to and take part in digital exchange, irrespective of their chosen technology (i.e., a technology agnostic solution).

Global identity standards will pave the way for the digital transmission and the airline industry is urging IATA to set the necessary standards for permanent and harmonized identity scheme, a clear guideline for issuing identities and a single centralized repository for maintaining and distributing the IDs with relevant information such as connectivity channels/routing. Unlike traditional standard setting activities, it would be rather a difficult task as it requires new identity management standards to be interoperable with the existing identities management practices.

## Single Centralized System

**Generate  
Permanent IDs**

Unique identity for each  
branch office on permanent  
basis

**Provide  
Mapping**

Establish mapping with  
existing identities/CCSs

**Distribute  
IDs**

Distribute identities  
with the partners i.e.  
Carrier, CCS etc.

**Setup  
IDs lifetime**

No need to change and setup  
IDs when you change your  
messaging partner

IATA is well-regarded for leading the airline industry towards common global standards. IATA needs to define a strategy to take advantage of the potential offered by the rapid progress of digital technologies to generate smart, sustainable, and inclusive growth in the air cargo industry.

Standardizing the identity management practices would open the door for a digital revolution in air cargo and lead the industry towards a digital transformation.

For further information, please visit [www.iata.org/cargo-xml](http://www.iata.org/cargo-xml) or contact us at [Cargoxml@iata.org](mailto:Cargoxml@iata.org)

[www.iata.org](http://www.iata.org)